

**STANDARD FOR WATER STORAGE
TANKS FROM 150 LITRES TO 500
LITRES. FOR DOMESTIC USE.**

NO: T.E.L. - 712 - Rev 1-2019

**STANDARD FOR WATER TANKS FROM
150 LITERS TO 500 LITERS. FOR
DOMESTIC USE.**

STANDARD FOR WATER STORAGE TANKS FROM 150 LITRES TO 500 LITRES. FOR DOMESTIC USE.

NO: T.E.L. - 712 - Rev 1-2019

1.0 SCOPE:

This standard which specifies the requirements of water tanks for booster pumps ranging from 150 liters to 500 liters for the storage and the supply of water to a domestic home. This standard applies to tanks with a capacity of 150 liters ranging up to 500 liters.

The purpose of the standard is to define the material used, requirements, tests, type of tests and production quality control tests.

Companies manufacturing to the standard must have a management system complying with I.S. EN 9002 or equivalent.

2. NORMATIVE REFERENCE

This Standard incorporates by dated or undated reference from other publications. These 'normative' references subsequent amendments to, or revisions of, any of these publications apply to this standard only when incorporated in it by amendment or revision. For undated reference the latest edition of the publication referred to applies.

ISO	1133 - 1981	Plastics Determination of the Melt Flow Rate of Thermoplastics
ISO	1183	Plastics: Method of determining density
ISO	R527	Determination of Tensile Properties
ISO	175	Plastics: Determination of the effects of liquid chemicals, including water
ISO	1872 - 1986	Plastics: Test specimen preparation
EN	45020	General terms and their definition concerning standardisation and related activities

3. DEFINITION

Water tanks for booster pump use.

An enclosed tank that retains its designed shape for the purpose of holding water for the use within domestic dwelling. The Tank is designed with flat surfaces to allow the fitting of plumbing fittings. The lid should be removable, however should be sealable when closed. The product should be a single skin rotationally moulded product. The tank design should be such that there are no areas where water could become stagnant.

STANDARD FOR WATER STORAGE TANKS FROM 150 LITRES TO 500 LITRES. FOR DOMESTIC USE.

NO: T.E.L. - 712 - Rev 1-2019

4. DESIGN REQUIREMENTS

4.1 *Surfaces:*

Flat surfaces are to be incorporated in to the tank where necessary, for the purpose of securing plumbing fittings.

4.2 *Supports:* The water tank should be self-supporting. When filled with water it should be self-supporting and not need any additional support other than a solid level surface to rest upon, which should extend over the full base of the tank.

4.3 *Handling:* Water tank should have holding features for easy of handling on site.

4.4 *Lid:*

The tank shall have a closed fitting rigid lid secured by means of threaded feature which excludes light and ingress of particles and / or insects. Where a connection passes through the tank a means of sealing any opening should be provided.

5. MATERIAL PROPERTIES:

5.1 *Density - (Raw materials)*

The tank is to be made with a UV stabiliser resin polymer that is Water Regulation Advisory Scheme (WRAS) Approved.

Determined in accordance with ISO 1183 method A or D. A resin polymer shall have a density not less than 920kg/m³ and not greater than 949kg/ m³.

5.2 *Melt Flow Rate - (Raw materials)*

The Melt Flow Rate is measured in accordance with ISO 1133 Section 4, must be a maximum of 7g/10min and a minimum 2g/10min. Test to be carried out on raw material.

5.3 *Weather Resistance*

The material used in the manufacture of the body shall be ultra violet light stabilised not less than UV8.

STANDARD FOR WATER STORAGE TANKS FROM 150 LITRES TO 500 LITRES. FOR DOMESTIC USE.

NO: T.E.L. - 712 - Rev 1-2019

6. Water tanks

6.1 Capacity and Tolerance

(a).When tested the ambient temperature shall be $15^{\circ}\text{C} \pm 5^{\circ}\text{C}$. The Tank shall be filled to overflow point with water, wait ten minutes fill to overflow fitting, and measure the capacity to an accuracy of $\pm 3\%$.

(b) The stated capacity shall be the measured capacity $\pm 10\%$ stated in litres.

6.2 Visual inspection

On visual inspection of the tank there should be no bubbles, blisters, or other defects that could cause a hole or fracture.

6.3. Weigh

The weight of the tank with all its fittings attached shall not exceed 40KG.

6.4 Wall thickness

The minimum wall thickness on any point of the sides or base shall not be less than 4.5mm. A margin of $\pm 10\%$ is permitted.

6.5. Drop Test ; testing of Water Tank

The water tank should be tested as follows:

(a) A water tank shall be placed on a firm level surface.

(b) The temperature at test shall be $20^{\circ}\text{C} \pm 5^{\circ}\text{C}$

(c) A load of 5Kg should be placed in a drop test tube with a height of not less than 4 Metres and released; note measurement 3 below is 4 metre for this test.

(d) The test shall be performed the surface sides; on the base of the unit as it sits on the level base and on the top rim of the tank

Results:

(i) No failure or fracture of the Water Tank shall occur.

(ii) No permanent deformation of the Tank on any part shall occur.

Drop test in accordance with European Standard EN840 Part 5 Similar conditions as applicable shall apply in the water tank Drop Test

STANDARD FOR WATER STORAGE TANKS FROM 150 LITRES TO 500 LITRES. FOR DOMESTIC USE.

NO: T.E.L. - 712 - Rev 1-2019

EN 840-5:2004 (E)

4.7 Tests on the containers

4.7.1 General

All tests shall be carried out on new containers.

4.7.2 Impact tests by ball drop

The ball drop test is not compulsory for steel containers.

The ability of sensitive points of the container to resist impacts at low temperature shall be tested under conditions in 4.4.

The 2-wheeled containers shall be placed on a concrete or steel surface in the normal position.

There shall be a steel frame between the concrete surface or the steel surface and the container so that the complete area of the bottom of the container can be deflected during the test.

The 4-wheeled containers shall stand on their wheels.

Ball drop tests shall be carried out using a 5 kg steel cylinder, diameter 65 mm, with hemispheric end radius of 32,5 mm. The steel cylinder is guided in a vertical pipe with a slot or with holes in order to allow the air to escape during the drop.

The device shall be according to Figure 1.

Dimensions in mm

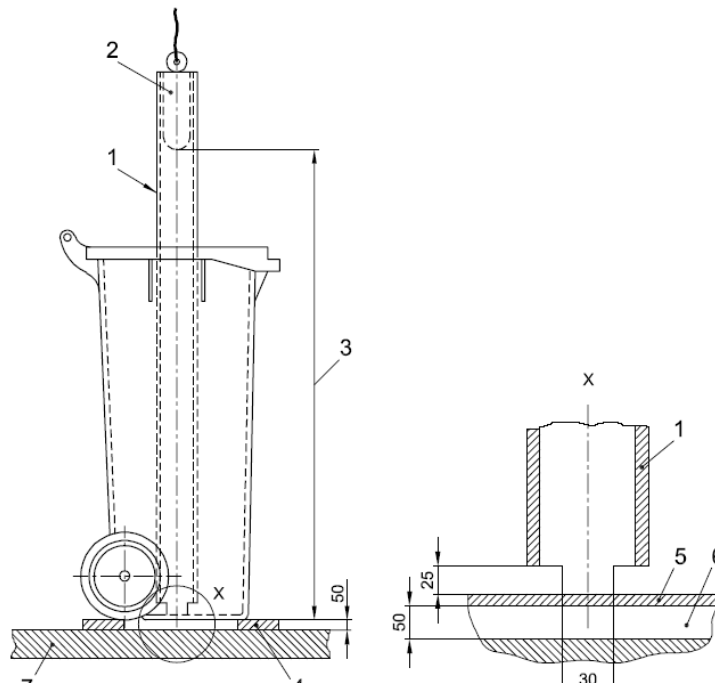

STANDARD FOR WATER STORAGE TANKS FROM 150 LITRES TO 500 LITRES. FOR DOMESTIC USE.

NO: T.E.L. - 712 - Rev 1-2019

Key

1	Vertical (plastic) pipe (inside diameter: 70 mm)	6	Free room
2	Steel cylinder (diameter: 65 mm; 1 hemispheric end; mass: 5 kg)	7	Concrete or steel surface
3	Height fall (0,80 m)		
4	Steel frame (see 4.7.2)		
5	Container bottom		

Figure 1 — Device for ball drop test

6.6 Test frequency

- (i) Weight: The weight of the Tank as defined in 6.3 shall be tested every 300 products. Samples randomly picked before dispatch.
- (ii) Capacity: As defined in 6.1 is a type of test that is completed prior to certification, once off.
- (iii) Visual inspection: Every Tank
- (iv) Wall thickness: Once every 300 mould runs, from samples randomly picked from production.

6.8 Parts

Any additional fittings to the tank shall comply with BS 6920 and EN 13341 standards. Fittings that are for the use in the tanks may be brass or PVC fittings.

6.8.1 A warning pipe termination assembly shall be provided for fitting through the side wall of the tank and for connection to an external warning pipe. It shall incorporate a turn-down inside the tank with its outlet 50 ± 10 mm below the shut-off water level and a free-draining watertight housing, containing a screen, for fitting to the warning pipe outside the tank. The screen shall have apertures not exceeding $0.65 \text{ mm} \times 0.65 \text{ mm}$, shall not restrict the full flow of the warning pipe and shall be easily removable for inspection and cleaning.

6.8.2 All products and components covered by this standard which contain non-metallic materials and are liable to come into contact with water shall comply with of BS 6920. All materials in contact with or likely to come into contact with potable water shall not constitute a toxic hazard, shall not support microbial growth and shall not give rise to unpleasant taste or odour, cloudiness or discoloration of the water.

STANDARD FOR WATER STORAGE TANKS FROM 150 LITRES TO 500 LITRES. FOR DOMESTIC USE.

NO: T.E.L. - 712 - Rev 1-2019

7.0 MARKINGS:

The following information should be marked on each Water Tank:

Tool markings – to be able to identify the date of production and full tractability.

Information on the tank:

- (i) the manufacturer's name or trade mark;
- (ii) the words :”This tank is manufactured to standard T.E.L. 712 Rev 1 – 2019”
- (iii) capacity in litters.

8.0 PRODUCTION AND QUALITY CONTROL

The tests described in section 6.6 of this standard should be carried out at the frequency indicated above during production, quality control, and records maintained within a quality system.

9.0 THERMAL INSULATION

This tank shall be of such a design as to facilitate the installation of an insulation jacket where the regulations require its use.

10.0 References

References should be made to the following:

The installer of the tank should comply with relevant local authority's standards and should refer to the following standards:

BS 7181: 1981 where applicable

BS 4213: Specification for cold water storage and feed and expansion cisterns (polyolefin or olefin copolymer) and cistern lids.

BS 5750: Quality systems.

BS 6920, Suitability of non-metallic products for use in contact with water intended for human consumption with regard to their effect on the quality of the water.